

ARCHIVED COPY:

DO NOT USE

RS
ystem
ual



Contents

CONTENTS.....	1
CONVENTIONS USED IN THIS DOCUMENT	4
<i>Warning:</i>	4
<i>Caution:</i>	4
.....	4
ARCHIVED COPY:	5
.....	5
.....	5
.....	5
DO NOT USE	5
.....	5
CONTRAINDICATIONS.....	5
THE TORS SYSTEM	6
GENERATOR	6
<i>Front Panel</i>	6
<i>Rear Panel</i>	6
<i>TORS Transducers & Cables</i>	7
SAFETY 	8
WARNINGS.....	8
CAUTIONS.....	9
ELECTROMAGNETIC INTERFERENCE	9
COMPLICATIONS AND POTENTIAL SIDE-EFFECTS.....	10
SERIOUS INCIDENT	11
INSTRUCTIONS FOR USE	12
SETTING UP THE TORS SYSTEM	12
<i>Power up the Generator</i>	12
<i>Optional - Attach the "Cement" footswitch to the Rear Panel</i>	12
<i>Assemble the Cement Transducer + Probe</i>	13
<i>Cement Transducer - Connect</i>	14
<i>Cement Transducer - Initialise</i>	14
<i>Cement Transducer - Activate</i>	14

<i>Cement Removal – Irrigation</i>	15
<i>Fume Extraction</i>	15
<i>Performance Characteristics</i>	15
<i>Turn Off TORS</i>	15
FAULT / WARNING INDICATORS: (SEE ALSO APPENDIX 4: TONES AND BEEPS)	16
DECONTAMINATION	17
• <i>After Use Re-Processing</i>	17
• <i>Single Use Items</i>	17
• <i>Reusable Items</i>	17
• MANUAL CLEANING	17
• AUTOMATED CLEANING	17
• CLEANING INSPECTION	17
• WRAPPING	17
• STERILIZATION	17
• <i>End of Life Management</i>	17
• <i>Opened in Error</i>	17
• <i>Cleaning the Generator</i>	17
• <i>Cleaning the Footswitch</i>	17
REPROCESSING GUIDELINES: IMMEDIATELY AFTER USE IN OPERATING THEATRE	19
EQUIPMENT CARE	19
<i>Probe Inspection</i>	19
<i>Transducer / Probe Usage</i>	19
<i>Storage of Equipment between Cases</i>	19
<i>Maintenance</i>	20
<i>Technical Support</i>	20
APPENDICES	21
APPENDIX 1: MARKINGS ON THE TORS FRONT AND BACK PANELS	21
APPENDIX 2: TORS (SERIES 1) PARTS LIST	23
APPENDIX 3: ELECTROMAGNETIC INTERFERENCE	24
APPENDIX 4: TONES AND BEEPS	26
APPENDIX 5: REAR PANEL MESSAGES	27
APPENDIX 6: TECHNICAL SPECIFICATION	28
APPENDIX 7: WARRANTY STATEMENT	28

Conventions used in this document

Warning:



A statement that if not strictly followed could result in injury or loss of life, or a statement that is otherwise required to be a warning.

Caution:

A statement that if not strictly followed could result in damage to the equipment

Contact Information

If the unit requires repair, please contact us through your local supplier or directly:

Radley Scientific Ltd.
Bremridge House
Bremridge
Ashburton
S. Devon
TQ13 7JX
UK

Tel: +44 (0)1364 653899

www.tors.co.uk

Intended Purpose

TORS is an ultrasonic surgical device intended to be used for removal of polymethylmethacrylate (PMMA) bone cement in orthopaedic applications.

Intended user

TORS is intended to be used by surgical staff experienced with the operation of ultrasonic devices for cement removal in a professional clinical setting. See relevant Warnings.

Target Population

There are no specific restrictions based on age, weight, health status or ethnicity. No specific patient populations have been defined but patients with contraindication are to be excluded, see Contraindications.

Clinical Benefit

- During treatment with TORS, the patient benefits from the ultrasonic bone cement removal.
- The use of an ultrasonic device for cement removal provides clinical benefit over mechanical cement removal methodologies, due to decreased trauma for the patient, leading to shorter recovery times.

Please note:

- This document does not reference surgical techniques.
- The safety & effectiveness of any ultrasonic surgical equipment is mostly dependent upon the surgeon and nursing staff.

Indications

TORS is indicated for use in the removal of polymethylmethacrylate (PMMA) bone cement in orthopaedic applications.

Contraindications

- Do not use, if in the judgment of the surgeon, the use of ultrasonic surgical techniques is not in the best interest of the patient.
- Do not use for incising bone.

Please read all Warning & Cautions contained in this document

The TORS System

Generator

Front Panel

The screen is highly visible, especially in a darkened operating theatre, indicates operating mode selected and gives concise instructions on action required in the event of disruption to normal operation.

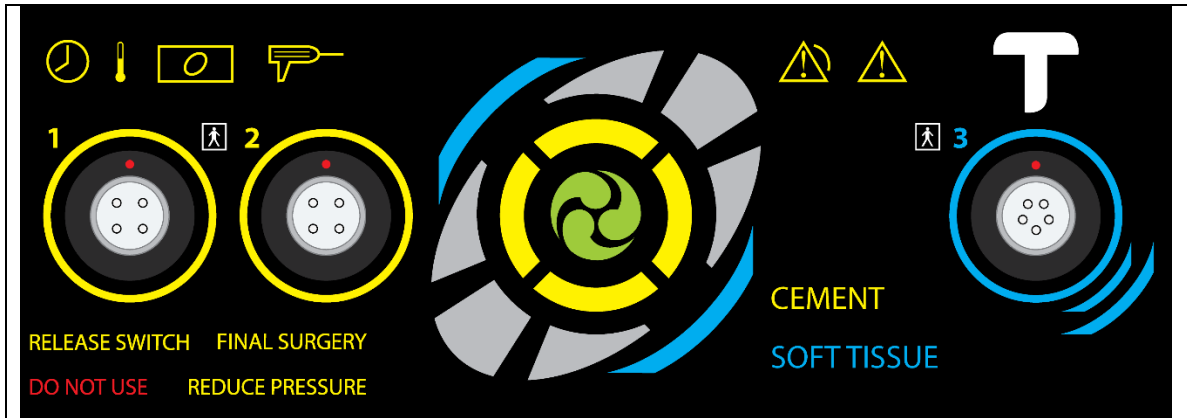

Figure 1: TORS Generator Front Panel

Rear Panel

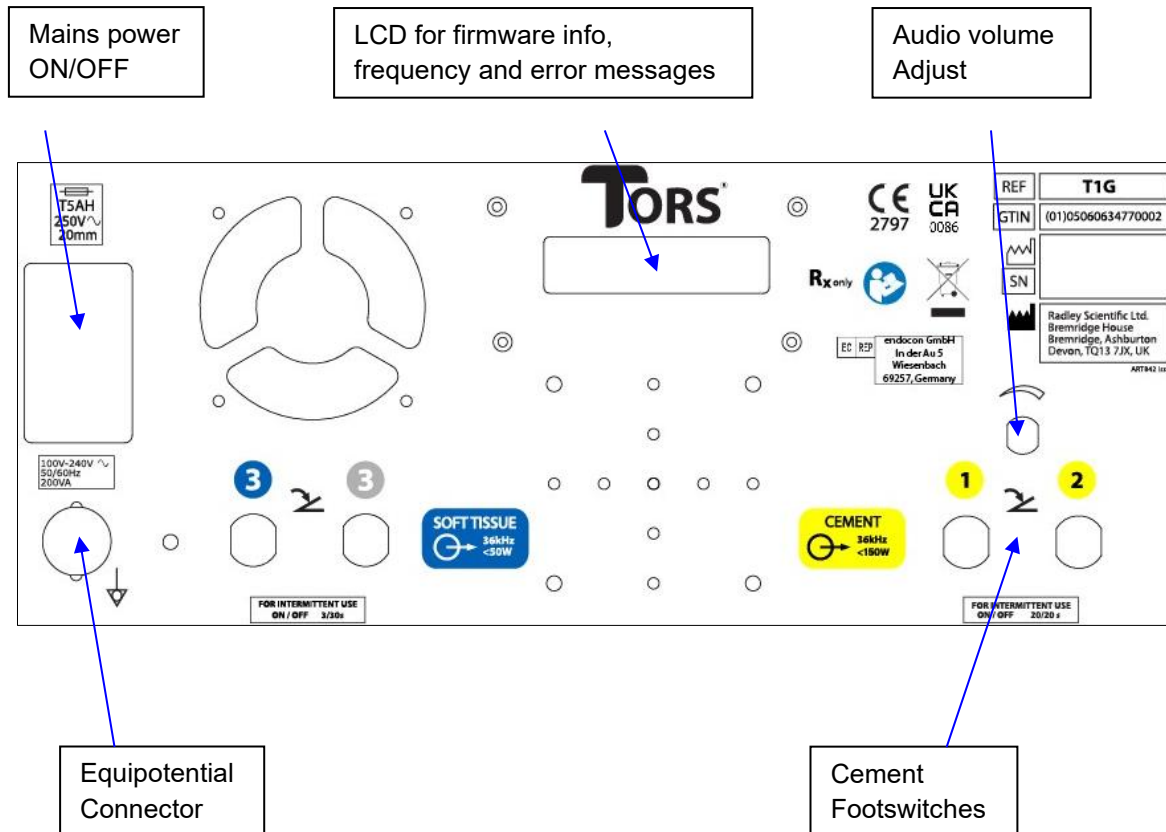
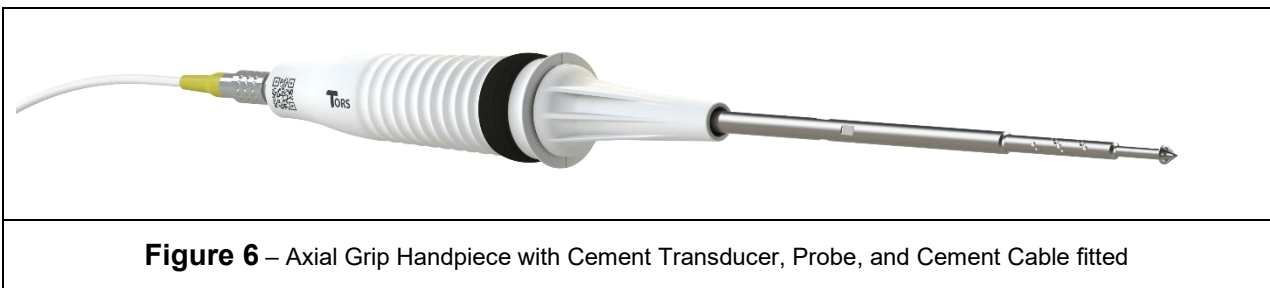
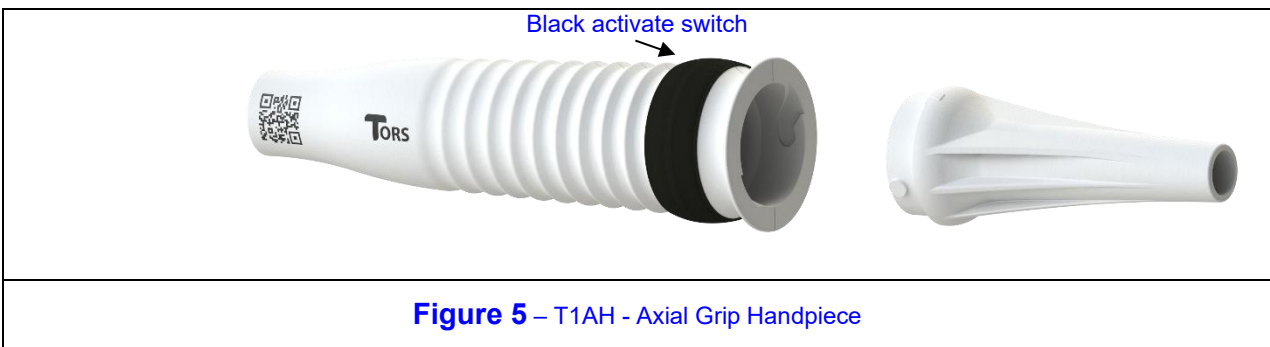
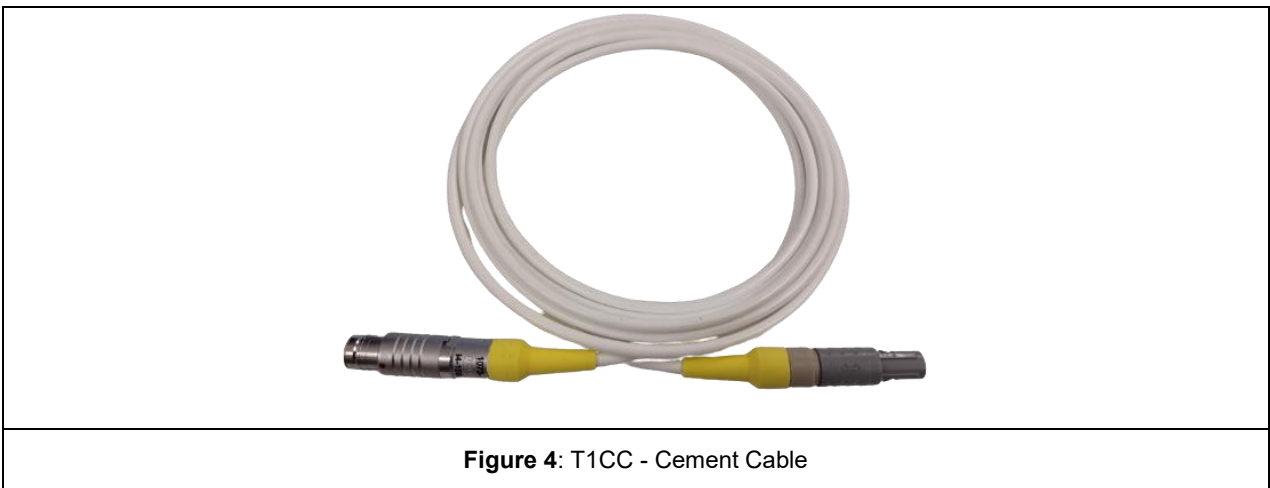
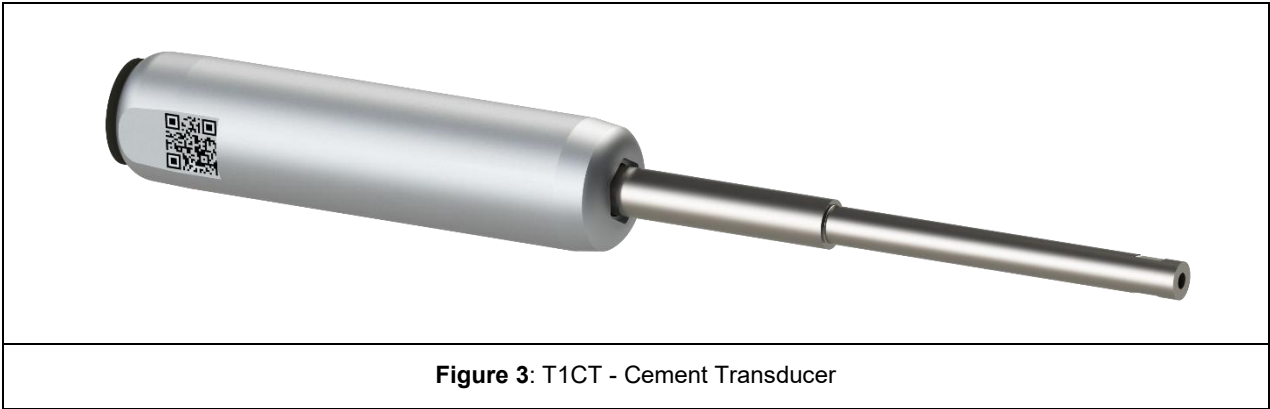

Figure 2: TORS Generator Rear Panel

There is only one user control on the Generator itself:

- Volume control (on the rear panel)

TORS Transducers & Cables



Safety

Warnings

- The chisel probe is for cement removal only, whilst it is similar in appearance to osteotomy probes from competitor devices, TORS is NOT currently indicated for bone cutting.
- This device should only be used by surgeons who are (1) trained in the types of surgical procedures that are to be carried out and (2) trained in the specific use of ultrasonic surgical instruments.
- Do not operate TORS in a potentially explosive or flammable area, or in oxygen rich environments. Note that if the Probe touches anything metal while **active**, sparks may be produced.
- The use of TORS in cases where a patient or an operator of the unit has been fitted with a cardiac pacemaker is left to the discretion of the consultant in charge of the procedure although no electrical flow is made through or into the patient and many clinical papers on the use of ultrasound in the proximity of cardiac pacemakers have been published.
- Appropriate protective measures, including smoke evacuation, should be taken to protect users from any smoke, or other aerosols, produced by the use of surgical ultrasound.
- Use extreme caution when using in the vicinity of nerves.
- Handle reusable parts correctly in order to achieve full service-life.
- No modification of any part of this equipment is allowed.
- The use of transducers or handpieces not supplied as part of the TORS system may damage the Generator and create a safety hazard for the operator and patient.
- Avoid touching or holding the **probe tip** at the end of the **active** probe. **Danger of burns!**
- Other than the **active** tip, do not allow probe to be in contact with tissue.
- Irrigate the femoral canal after each activation.
- If the probe is deactivated inside heated PMMA it is possible the cooling cement will adhere very strongly to the probe, in which case it may become difficult to reactivate the probe in order to remove it from the cement.
- When guiding the TORS Cement Probe through PMMA, care must be taken not to exert excessive force in order to maintain control of the direction of travel of the probe.
- Use of excessive force in vicinity of thin bone may cause perforation.
- Avoid resting the **hot probe tip** on skin or other tissue for at least 10 s after cessation of activation as it will have become hot while cutting. Ultrasonic systems dissipate heat quickly. (User may quench hot probe tip in saline.)
- Care should be taken when in contact with tissue between activations, in case accidental activation should occur.
- If the probe comes into contact with bone, using recommended cooling strategies a bone temperature of up to 51°C may be seen.
- Allowing active tip to contact bone may cause damage to the bone.
- Wherever possible avoid contact between the side of active cement probe and patient tissue.
- Mains isolation is achieved by use of the double pole switch located on the rear panel. DO NOT position the equipment in such a way as to make access to this disconnection switch difficult.
- To avoid the risk of electric shock, this equipment must only be connected to a main's supply with protective earth.
- TORS is not MR safe or MR compatible.
- Do not re-sterilize or reuse any single use parts.
- Portable RF communications equipment (including peripherals such as antenna cables and external antennas) should be used no closer than 30 cm (12 inches) to any part of TORS, including cables specified by RSL. Otherwise, degradation of the performance of this equipment could result.
- TORS should not be used adjacent to or stacked with other equipment. If adjacent or stacked use is necessary TORS should be observed to verify normal operation in the configuration in which it will be used.
- The use of accessories, transducers and cables other than those specified may result in increased emissions, decreased immunity or improper operation.
- There are no user serviceable parts.

Cautions

- U.S. law restricts this device to sale by or on the order of a licensed physician.
- The nursing staff must be trained so that they are familiar with the equipment to be used.
- Avoid allowing an **active** probe to come into contact with any metal surface.
- Do not sterilize the TORS generator or footswitch.
- Do not block or otherwise restrict the vents on the rear and bottom panels.
- Never allow electrosurgical equipment to contact the probe.
- Always transport TORS using the supplied transport cases.
- The TORS generator has an Equipotential Terminal on the back panel. This is provided for compatibility with other medical systems requiring such connections. This conductor is not intended for protective earthing. Refer to EN 60601-1 for details of use with ME Systems.
- TORS:
 1. should be used only for those procedures for which it is indicated.
 2. should be used with an appropriate power level commensurate with the required task.
 3. should be used with correct surgical technique.

If used correctly the TORS should remove PMMA cement to the satisfaction of the user.

The equipment should inform the user of its status either by audio or visual means, particularly if ultrasound output is not possible. However, if a fault with the audio or visual indicators occurs whilst a cut is in progress, it may allow that cut to be completed without indication.

Electromagnetic Interference

- This equipment is only suitable for use in hospital operating theatre / operating room.
- The performance of TORS may be degraded if it is subjected to electromagnetic disturbances e.g. an incorrect display that clears automatically once activate switch is pressed/depressed.
- Do not use TORS simultaneously with laser equipment or high frequency surgical equipment.
- This equipment has been tested and found to comply with the limits for a medical device.

However, should interference occur, the user can try the following measures

1. Turn equipment off and on to confirm the source of the interference.
 2. Increase separation between this equipment and other devices.
 3. Connect this equipment to a power socket different from that to which the other devices are connected.
 4. Consult medical physics department.
- The EMISSIONS characteristics of this equipment make it suitable for use in industrial areas and hospitals (CISPR 11 class A). If it is used in a residential environment (for which CISPR 11 class B is normally required) this equipment might not offer adequate protection to radio-frequency communication services. The user might need to take mitigation measures, such as relocating or re-orienting the equipment.
 - Where replacement transducers and cables are required, these must be manufactured by RSL (see Appendix 2 for full listing),
 - See also Appendix 3: Electromagnetic Interference.

Complications and Potential Side-effects

General risks and complications of arthroplasty surgery

- Bone loss during prosthesis and/or cement removal
- Cortical perforation
- Fracture in the bone around the artificial joint
- Recovery time, pain and potential for arthritis associated with deliberate osteotomy
- Nerve / vascular lesions
- Rebleeding or haematoma / seroma
- Ligament, artery or nerve damage in the area around the knee joint
- Blood clots or deep vein thrombosis or pulmonary embolism
- Haemorrhage caused by tissue injury or ineffective haemostasis
- Bone / joint infection
- Late infection
- Infection of the wound and/or the tissue around the artificial joint
- Thromboembolism
- Implants or metal parts remaining in joint
- Fatigue fracture
- Excess bone forming around the artificial joint (knee) restricting movement
- Excess scar tissue forming and restricting movement
- Kneecap or hip dislocation
- Numbness in the vicinity of the wound scar
- Loosening of the artificial joint (normally after 10-15 years)
- Joint wear and tear
- Joint stiffening
- Bone Cement Implantation Syndrome (BCIS)
- Hypoxia
- Hypotension
- Cardiac arrhythmias
- Cardiovascular collapse
- Thermal injury due to cement polymerization (setting) reaction
- Contact inhalational exposure to PMMA monomer leading to hypersensitivity
- Asthmatic reactions
- Neurological symptoms
- Localized irritation
- Personal risks from anesthetic or the surgery itself

Potential side-effects of ultrasonic arthroplasty surgery

- Necrosis and clinical dysfunction in femoral cortex and surrounding soft tissue due to heat transmission from ultrasonic probe / cement interface
- Intramedullary canal perforation
- Different tissues and bone cement will be heated to different degrees with the same ultrasound parameters
- Each cell type has a different susceptibility to thermal injury
- Pathologic humeral fracture
- Microscopic bone cracks
- Plume production (95% water, 5% cell debris)

- Radial nerve palsy
- Risk of cross-infection from re-sterilized reusable parts of the system

Serious Incident

The Medical Device Regulation defines a serious incident as:

“...any incident that directly or indirectly led, might have led or might lead to any of the following:

- (a) the death of a patient, user or other person,
- (b) the temporary or permanent serious deterioration of a patient's, user's or other person's state of health,
- (c) a serious public health threat”

In the event that a serious incident occurs in relation to the TORS device, the user and/or patient should report the serious incident to the Manufacturer and to the Competent Authority of the state in which the user and/or patient is established.

Instructions for Use

Setting Up the TORS System

Power up the Generator

- Connect the mains lead to the rear panel of the Generator.
- Press the Mains rocker switch up, “I”, to switch on.
- The Generator will now power up with a flourish of tones, conduct a brief full screen illumination test as shown in Figure 7.

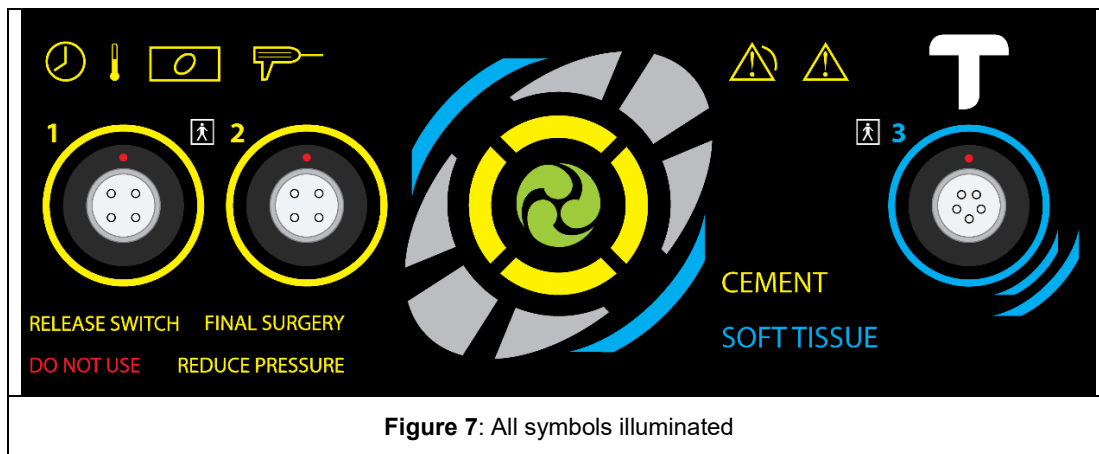

- After approximately one second the display will show:

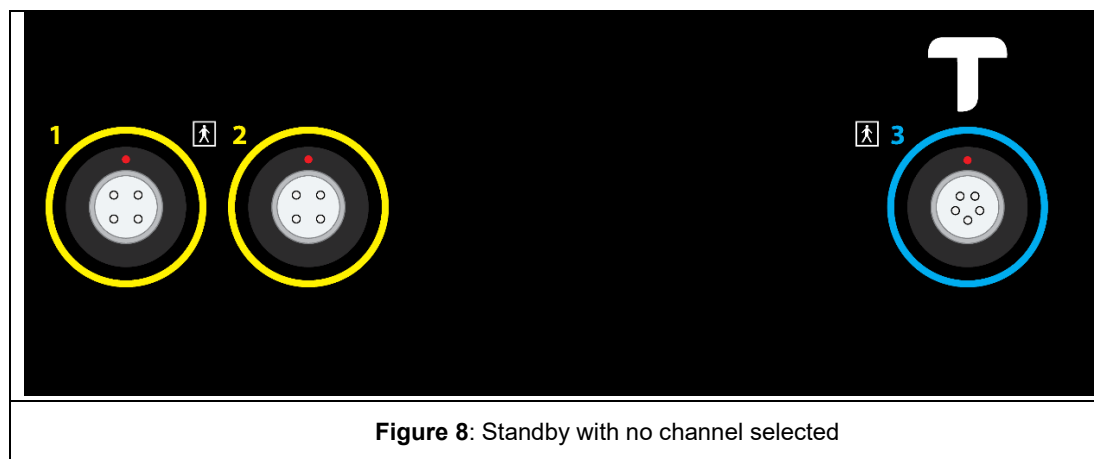

Optional - Attach the “Cement” footswitch to the Rear Panel

- The tube with the **Yellow** + “1” collar attaches to the similarly marked connection.
- The tube with the **Yellow** + “2” collar attaches to the similarly marked connection.

Assemble the Cement Transducer + Probe

- Select the pre-sterilized cement transducer.
- Select the appropriate pre-sterilized reusable probe.
- Select the sterile axial-grip handpiece (single use).
- Fit the transducer into the handpiece. Rotate the transducer and drop into place – ensure that it is securely connected. See (1) & (2) in Figure 9 below.
- Slide the handpiece sleeve over the Transducer horn. Locate the lugs at the base of the sleeve into the handpiece grip and twist / click into place. See (3) below.
- Attach the probe to the transducer using both spanners. See pictures (4) and (5) below.
- **ALWAYS** use **BOTH** spanners for tightening the probe to avoid damaging the cement transducer.

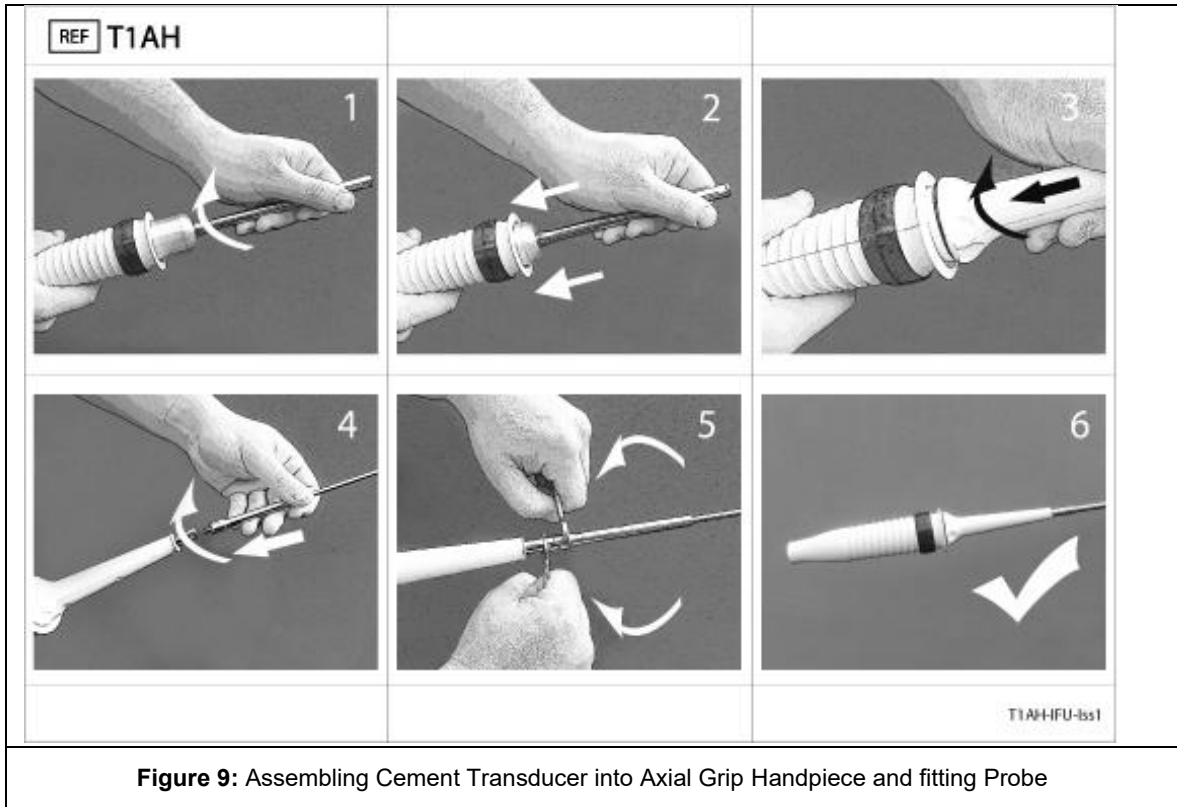

Figure 9: Assembling Cement Transducer into Axial Grip Handpiece and fitting Probe

Cement Transducer - Connect

- Connect the Cement cable (Yellow coding to Generator Channel 1 or 2 (Yellow rings) by aligning the red dot on the metal plug with the red dot on the Generator socket. Push the plug into the socket until it clicks.
- Connect the other end of the Cement cable (Plastic connector) to the Cement handpiece. Align the arrow on the plastic connector with the spaces separating the two slots in the rear connector on the axial-grip handpiece. Click into place.
- To remove, pull back on the knurled part of the plug - **Do not** pull the cable.

Cement Transducer - Initialise

- When the surgeon is ready to use the transducer, they must initialize it to enable power. This is done simply by pressing the black activate button on the handpiece or the yellow footswitch (Ch1 or Ch2). The display shows:

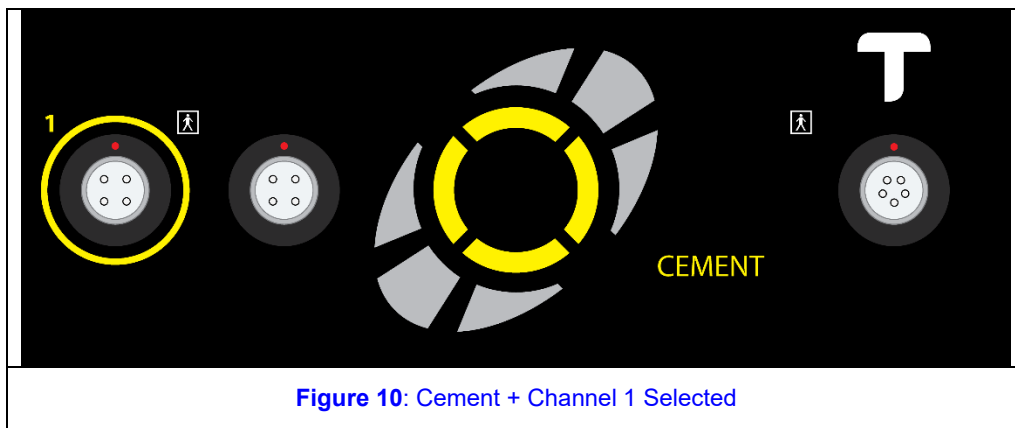

Figure 10: Cement + Channel 1 Selected

Cement Transducer - Activate

- Press the black activate button on the Handpiece or the yellow Footswitch. This will **activate** the Transducer and Probe for surgery. An audible indicator signifies the probe is active with a continuous low-pitched tone.

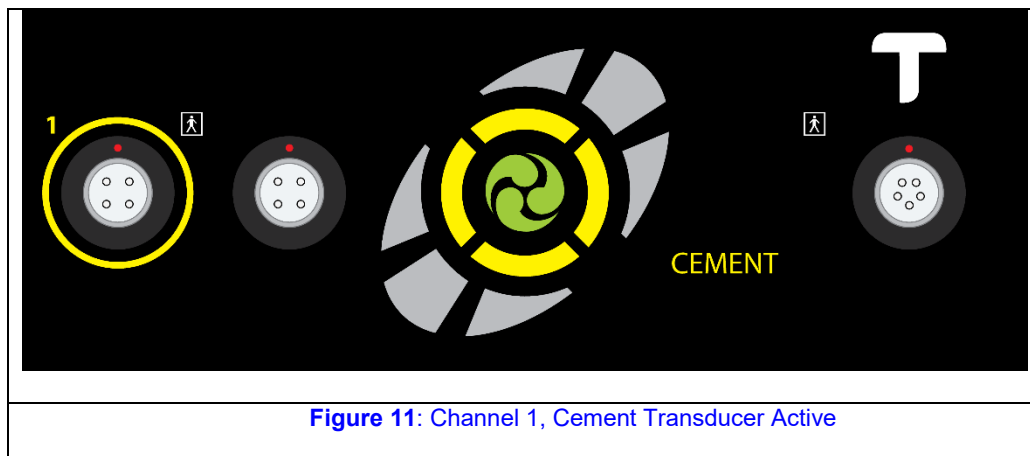

Figure 11: Channel 1, Cement Transducer Active

- To stop output, release the Footswitch or activate button.
- If the Footswitch or activate button is held down continuously for 20 seconds the audio indicator sound will change from continuous to pulsed.
- After a further 5 seconds the Generator will terminate power.
 - Output power is cut
 - Audible indicator stops
 - Displays Warning symbol + Transducer symbol + Clock symbol.
- These will remain illuminated as long as the Footswitch or activate button pressed.
- When it is released, normal operation resumes

Cement Removal – Irrigation

It is important to irrigate the bone canal during the cement removal process for two reasons: - It clears the canal of cement debris, including dust, and it also helps maintain safe operating temperatures within the canal. Such irrigation systems are standard provision in orthopaedic cases.

It is recommended that irrigation in the form of pulsed lavage or manual irrigation is used after each activation of any probe-type, piercer or scraper.

Do not irrigate *during* an activation as this may compromise the efficacy of the ultrasound transmission, translating to a slower cement removal process. The TORS probes are designed to produce rapid heating at the probe / PMMA interface, thus softening the cement. Any cooling during this process will impede the desired effect.

Any waste products should be disposed of as per normal hospital procedures.

Fume Extraction

It is recommended that a suitable extraction system is used to remove smoke, aerosols and any associated odors.

Any waste products should be disposed of as per normal hospital procedures.

Performance Characteristics

- Cement Removal

The different diameters of piercer probes will penetrate cement at different rates but the size range allows access into varying open cement canal diameters with consequent varying volumes of cement removed per “cut”.

Likewise, the different scraper probe sizes will remove varying volumes of material per “cut”.

The 4 mm piercer (P4R2) is intended specifically for penetrating hard, High-Density Polyethylene (HDPE), cement restrictors (distal plugs). It has no proximal cement trapping flange and will not remove material. Once an initial hole has been made larger piercers and scrapers can be used to erode and remove the plug. It is not recommended for use on the softer, PMMA, or gelatine, distal plugs.

The user should not apply excessive force, but instead, allow the ultrasound to advance the probe through the cement.

PMMA will not cause wear/damage to the probes. If there is evidence of wear/damage on a probe, then this is likely to be caused by the probe making contact with either the bone or a metal obstruction (stem, screw, nail etc.)











If the probe heads contact bone, then an audible squeal provides feedback to the user. The user should immediately redirect the probe head to avoid contact with bone. Sometimes the audible response may be damped out when the bone cavity is still densely packed with bone cement, or the user may not be able to hear the very high pitch of the audible feedback from the probe head on bone.





If a TORS Piercer probe appears to be silent but NOT moving forward through material, or making smoke, then it may well be contacting bone. DO NOT CONTINUE TO PUSH without checking where the probe is. Real time X-ray is very effective at this point.

Turn Off TORS

- Press the black ON/OFF power switch at the rear of the unit. The screen will become entirely black.

Fault / Warning Indicators: (see also Appendix 4: Tones and Beeps)

 <p>The illuminated yellow triangle indicates that a fault has occurred.</p>	It will always be accompanied by:	
	i. An illuminated symbol indicating the part of the equipment where the fault has occurred	
		
	ii. Illuminated text instructing the user e.g. Reduce Pressure	<p>Or</p>  <p>Or</p>  <p>Or</p> 
	If warning relates to time, the clock symbol also illuminates	
If warning is temperature related the temp symbol also illuminates		
	<ul style="list-style-type: none"> • Too much force is being applied to the active transducer. Reduce applied force to improve performance. Excessive force whilst active will impede cutting performance. • No transducer connection. • Probe tip is too hot. Allow probe tip to cool. 	
	<p>Handpiece button or footswitch held in. A high-low tone will sound.</p>	
	<p>Generator has over-heated. Check air vent below generator is un-impeded. A high-low tone will sound. Try again after 5 -10 seconds.</p>	

 +  + 	<p>The generator has detected a problem with the connections to the transducer. The warning triangle will illuminate a high tone will sound and repeat 3 times. Switch OFF then ON to clear fault. Re-activate the transducer away from the patient – if fault recurs then change the transducer and return for service.</p>
 + 	<p>The Generator has detected a problem. The warning triangle will illuminate and a high tone will sound and repeat 3 times. Switch OFF then ON to clear fault. Switch generator back on – if fault recurs then return the system for service.</p>

Decontamination

Please refer to the separate Decontamination Certificate and Instruction (WIG0006 App1) provided with the Instrument Kit; this document provides all of the details for each of the following subjects:

- After Use Re-Processing
- Single Use Items
- Reusable Items
- Manual Cleaning
- Automated Cleaning
- Cleaning Inspection
- Wrapping
- Sterilization
- End of Life Management
 - A valid decontamination certificate MUST accompany any returned reusable accessories.
- Opened in Error
- Cleaning the Generator
- Cleaning the Footswitch

Reprocessing Guidelines: Immediately After Use in Operating Theatre

Refer to the separate Decontamination Certificate and Instruction (WIG0006 App1) provided with the Instrument Kit.

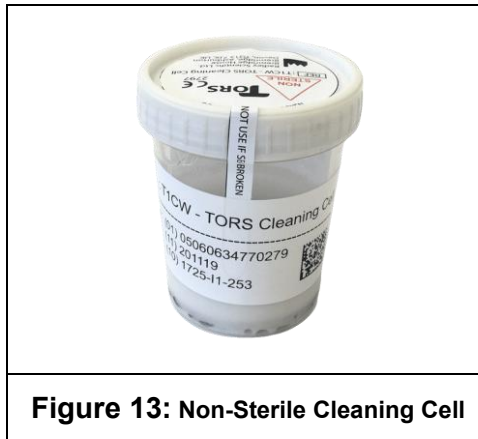

Figure 13: Non-Sterile Cleaning Cell

**IMPORTANT: The cleaning cell is NOT sterile.
NOT for use DURING procedure**

ONLY use at the end of the procedure prior to washing and re-sterilization of probes

Equipment Care

Probe Inspection

Before use it is recommended that the Probe be inspected for damage.

TORS probes are susceptible to damage if forced into contact with metal (e.g. hand instruments and clamps.) when active. The consequence of deformation or scratching a probe is to raise the mechanical stress in the region of the scratch (creating a “stress raiser”) when the probe is vibrating. If the stress is raised sufficiently there is a risk of the probe suffering metal fatigue and cracking. Fatigue failure is more likely if the stress raiser is close to one of the fixed points of maximum mechanical stress in the vibrating probe. If a probe does suffer metal fatigue as a result of a stress raiser causing a crack, the probe will no longer possess a resonant frequency “recognizable” by the generator and cannot be **activated** by the generator. Report to the supplier any transducer with a probe that has a scratch, if the scratch is deep enough to be detected by sliding a fingernail over it.

Transducer / Probe Usage

The cement transducers plus the cement probes of TORS can be decontaminated and reused. This is an important factor in reducing the cost per case. However, they cannot be reused indefinitely as probes will wear and the piezo crystals in transducers will depolarize over time and so service lifetimes are defined within which optimum performance can be expected. Therefore, probes and transducers must be replaced when needed.

The cement transducer lifetime is not limited by the system as its usage time is not monitored by the generator. It should be changed if cutting performance deteriorates. As a guide it may be changed after an average service life of 10 minutes ON-time per case, over 25 cases = 250 minutes ON-time.

All Cement Probes can be used for as long as they continue to soften and remove PMMA effectively as their usage time cannot be monitored by the generator. They should be changed if cutting performance deteriorates. As a guide they may be changed after an average service life of 5 minutes ON-time per case, over 50 cases = 250 minutes ON-time.

Storage of Equipment between Cases

It is recommended that the transducers (with associated cables) are stored, between cases, in a large autoclave tray provided and again, care should be taken to ensure that the cables are not kinked close to the connector.

Maintenance

The hospital is responsible for ensuring that the unit has an electrical safety check performed by qualified service personnel at least once a year.

Do not remove the covers from TORS.

TORS generator does not require periodic calibration. If the generator detects an internal problem, it will display a "Service Due" on the rear LCD. If this is seen, contact RSL to arrange repair.

There are no user-serviceable parts in TORS.

Any damage to the transducers or cables should be reported and the components returned to the supplier at the earliest opportunity.









Technical Support





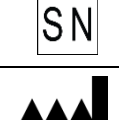

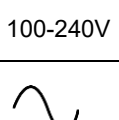
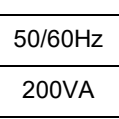
In line with the company's policy of quality assurance and customer care, RSL offers a telephone helpline service for users of TORS. This is provided by the TORS manufacturer, RSL at its facility in Devon, England.

HELPLINE Telephone number as displayed on the unit is: +44 (0)1364 653899

APPENDICES

Appendix 1: Markings on the TORS front and back panels

	Cement transducer selected
	Cement transducer output - Channel 1
	Cement transducer output – Channel 2
	Transducer active
	Model number
	Serial number
	Manufacturer
	Date of manufacture
	FUSE rating – Time delay, 5A, High breaking capacity, 250 Volts AC, size 20mm
100-240V	Mains AC voltage range
	Alternating current
50/60Hz	Mains AC frequency
200VA	Input power
	Warning sign
	Type BF equipment
36kHz	Cement frequency of output
<150W	Cement output power
For Intermittent Use ON / OFF 20/20s	Cement duty cycle

	Volume
	Footswitch connection
	Equipotential connection
	Output channel
	Follow instructions for use
	Electrical and Electronic equipment. Return waste to a collection system or treatment and recycling facilities. Follow decontamination instructions before returning waste.
	General caution sign

Appendix 2: TORS (Series 1) Parts List

ITEM	Product Code	GTIN
Cement Axial Grip Handpiece (Single Use)	T1AH	05060634770323
Cement 200 Ø4 Piercer Probe (Reusable)	P4R2	05060634770729
Cement 200 Ø6 Piercer Probe (Reusable)	P6R2	05060634770736
Cement 200 Ø8 Piercer Probe (Reusable)	P8R2	05060634770743
Cement 200 Ø10 Piercer Probe (Reusable)	P10R2	05060634770750
Cement 200 Ø6 Scraper Probe (Reusable)	S6R2	05060634770767
Cement 200 Ø8 Scraper Probe (Reusable)	S8R2	05060634770774
Cement 200 Ø10 Scraper Probe (Reusable)	S10R2	05060634770781
Probe Extension Bar - Straight (Reusable)	ESR1	05060634770989
Probe Extension Bar - Curved (Reusable)	ECR1	05060634770996
Cement Transducer (Reusable)	T1CT	05060634770064
Cement Cable (Reusable)	T1CC	05060634770071
Generator	T1G	05060634770002
Mains Power Cordset - JP	MPC-JP	05060634770965
Generator Carry Case	T1GC	05060634770040
Cement Footswitch	T1FC	05060634770019
Autoclave Tray	T1AT	05060634770095
Autoclave Tray Mat	T1SM	05060634770101
Instrument Carry Case	T1IC	05060634770118
Spanner	T1S	05060634770354
Probe Cleaning Cell	T1CW	05060634770279

Optional Extras

Cement 100 6mm Chisel Probe (Reusable)	C6R1	05060634771054
Cement 100 Ø6 Piercer Probe (Reusable)	P6R1	05060634770927
Cement 100 Ø8 Piercer Probe (Reusable)	P8R1	05060634770934
Cement 100 Ø6 Scraper Probe (Reusable)	S6R1	05060634770941
Cement 100 Ø8 Scraper Probe (Reusable)	S8R1	05060634770958
Probe Extension Bar - Long - Straight (Reusable)	ESR2	05060634770972
Generator Cart	T1C	05060634770347

Appendix 3: Electromagnetic Interference

Table 1

Guidance and manufacturer's declaration – electromagnetic emissions		
TORS T1G is intended for use in the electromagnetic environment specified below. The customer or the user of TORS should assure that it is used in such an environment.		
Emissions Test	Compliance	Electromagnetic environment - guidance
RF emissions CISPR 11	Group 1	TORS uses RF energy only for its internal function. Therefore, its RF emissions are very low and are not likely to cause any interference in nearby electronic equipment. TORS is suitable for use in all establishments other than domestic and those directly connected to the public low-voltage power supply network that supplies buildings used for domestic purposes.
RF emissions CISPR 11	Class A	
Harmonic emissions IEC 61000-3-2	No testing – not connected to public mains network	
Voltage fluctuations /flicker emissions IEC 61000-3-3	No testing – not connected to public mains network	

Table 2

Guidance and manufacturer's declaration – electromagnetic immunity			
TORS is intended for use in the electromagnetic environment specified below. The customer or the user of TORS should assure that it is used in such an environment.			
IMMUNITY test	IEC 60601 test level	Compliance level	Electromagnetic environment - guidance
Electrostatic discharge (ESD) IEC 61000-4-2	±8 kV contact ±15 kV air	±6 kV contact ±8 kV air (1)	Floors should be conductive. No synthetic material should be used in the environment. The relative humidity should be in the range 40% to 60%.
Electrical fast transient/burst IEC61000-4-4	±2 kV for power supply lines	±2 kV for power supply lines	Mains power quality should be that of a typical commercial or hospital environment.
Surge IEC 61000-4-5	±1 kV differential mode ± 2 kV common mode	±1 kV differential mode ± 2 kV common mode	Mains power quality should be that of a typical commercial or hospital environment.
Voltage dips, short interruptions and voltage variations on power supply input lines IEC 61000-4-11	0 % U_T ⁽²⁾ (100 % dip in U_T) for 0.5 cycle at: 0°,45°,90°, 135°,180°,225°, 270°,315° 0 % U_T (100 % dip in U_T) for 1 cycles 70 % U_T (30 % dip in U_T) For 25/30 cycles 0 % U_T (100 % interrupt in U_T) for 250/300 cycles	0 % U_T (100 % dip in U_T) for 0.5 cycle at: 0°,45°,90°, 135°,180°,225°, 270°,315° 0 % U_T (100 % dip in U_T) for 1 cycles 70 % U_T (30 % dip in U_T) For 25/30 cycles 0 % U_T (100 % interrupt in U_T) for 250/300 cycles	Mains power quality should be that of a typical commercial or hospital environment. If the user of TORS requires continued operation during power mains interruptions, it is recommended that TORS be powered from an uninterruptible power supply.
Power frequency (50/60 Hz) magnetic field IEC61000-4-8	3 A/m	No testing	No magnetically sensitive components.
<p>NOTES: <i>Mitigation applied because of environment.</i> U_T is the a.c. mains voltage prior to application of the test level.</p>			

Table 3

Guidance and manufacturer's declaration – electromagnetic immunity			
TORS is intended for use in the electromagnetic environment specified below. The customer or the user of TORS should assure that it is used in such an environment.			
IMMUNITY test	IEC 60601 test level	Compliance level	Electromagnetic environment - guidance
Conducted RF IEC 61000-4-6	3V rms 150kHz to 80 MHz Outside ISM bands 6V rms In ISM bands 0.15MHz to 80MHz 80% AM at 1kHz	3V rms 6V rms	Portable and mobile RF communications equipment should be used no closer to any part of TORS, including cables, than the recommended separation distance calculated from the equation applicable to the frequency of the transmitter. Recommended separation distance $d = 1.2\sqrt{P}$, 150 kHz to 80 MHz $d = 1.2\sqrt{P}$, 80MHz to 800MHz $d = 2.3\sqrt{P}$, 800MHz to 2.3GHz where P is the maximum power output rating of the transmitter in watts (W) according to the transmitter manufacturer and d is the recommended separation distance in metres (m).
Radiated RF IEC 61000-4-3	3 V/m 80MHz to 2.5GHz 9 V/m 710MHz, 745MHz, 780MHz, 5240MHz, 5500MHz, 5785MHz	3 V/m 9V/m	Field strengths from fixed RF transmitters, as determined by an electromagnetic site survey, ^a should be less than the compliance level in each frequency range. ^b Interference may occur in the vicinity of equipment marked with the following symbol.
Immunity to proximity fields from RF wireless communications equipment	27 V/m 385MHz 28 V/m 450MHz, 810MHz, 870MHz, 930MHz, 1720MHz, 1845MHz, 1970MHz, 2450MHz	27V/m 28V/m	
NOTE 1 At 80 MHz and 800 MHz, the higher frequency range applies NOTE 2 These guidelines may not apply in all situations. Electromagnetic propagation is affected by absorption and reflection from structures, objects and people.			
<i>a Field strength from fixed transmitters, such as base stations for radio (cellular/cordless) telephones and land mobile radios, amateur radio, AM and FM radio broadcast and TV broadcast cannot be predicted theoretically with accuracy. To assess the electromagnetic environment due to fixed RF transmitters, an electromagnetic site survey should be considered. If the measured field strength in the in the location in which TORS is used exceed the applicable RF compliance level above, TORS should be observed to verify normal operation. If abnormal performance is observed, additional measures may be necessary, such as re-orienting or relocating TORS.</i>			
<i>b Over the frequency range 150 kHz to 80 MHz, field strengths should be less than 3 V/m</i>			

Table 4

Recommended separation distances between portable and mobile RF communications equipment and TORS			
TORS is intended for use in an electromagnetic environment in which radiated RF disturbances are controlled. The customer or the user of TORS can help prevent electromagnetic interference by maintaining a minimum distance between portable and mobile RF communications equipment and TORS as recommended below, according to the maximum output power of the communications equipment.			
Rated maximum output power of transmitter	Separation distance according to frequency of transmitter		
	m		
	150 kHz to 80 MHz	80 MHz to 800 MHz	800MHz to 2.5 GHz
	$d = 1.2\sqrt{P}$	$d = 1.2\sqrt{P}$	$d = 2.3\sqrt{P}$
0.01	0.12	0.12	0.23
0.1	0.38	0.38	0.73
1	1.2	1.2	2.3
10	3.8	3.8	7.3
100	12	12	23
<p><i>For transmitters rated at a maximum output power not listed above, the recommended separation distance d in metres (m) can be estimated using the equation applicable to the frequency of the transmitter, where P is the maximum output power rating of the transmitter in watts (W) according to the transmitter manufacturer.</i></p> <p><i>NOTE 1 At 80 MHz and 800 MHz, the higher frequency range applies</i></p> <p><i>NOTE 2 These guidelines may not apply in all situations. Electromagnetic propagation is affected by absorption and reflection from structures, objects and people.</i></p>			

Appendix 4: Tones and Beeps

Rising flourish	TORS is booting to standby mode
No Tone	TORS is in standby mode
Triple tone – low-medium-low pitch	Handpiece activate button has been pressed to initialize handpiece (cement)
Continuous low-pitched tone	Acoustic output for the cement transducer
Double beep –high>low pitch	The Generator has reset itself after a minor problem such as time-out or over-temperature but the most common event is frequency mis-tuning due to probe over-damping. So, generally this tone means: “Over-loaded probe, reduce pressure and try again”
Triple beep – high>high>high pitch	A more serious problem has been detected.

Appendix 5: Rear Panel Messages

The LCD on the rear panel will display messages that indicate the status of the equipment. The following table shows the possible displays:

Message	Status	Action required
Radley Scientific Ltd TORS Issue x	Start up message. Shows the Issue number of the software "X"	Now awaiting transducer to be plugged in
Cement Ready	The toggle switch has been operated and the relevant transducer is ready to be activated.	Now awaiting use
36000Hz Cement Active	While transducer is active the top line will show the frequency. After releasing the switch it will display the final running frequency.	No action required
Active Too long Release Switches	The active button has been held on for too long. No output.	Release activate button on handpiece or on footswitch
Release Switches	Either activate or toggle button (or Footswitches) has been pressed at switch on.	Release activate or toggle button when switching on generator
Check Transducer Ease Grip and Retry	Transducer has been loaded too heavily	Release switch, then reactivate using less pressure on the jaw
	Transducer is too hot.	Allow transducer to cool.
Change Transducer Restart	Transducer frequency too low and feedback signal is low.	Switch supply off & on. Replace transducer if seen 3 times.
Transducer Leakage Change Tdcr	Generator has detected voltage on the transducer.	Switch supply off & on. Replace transducer if seen 3 times.
Frequency Error Service due	The generator has detected a serious internal problem.	Switch supply off & on. If message seen again generator requires service.

Appendix 6: Technical Specification

Model Nos:	See Appendix 2
Dimensions:	Generator: 340 mm (width) x 95 mm (height) x 375 mm (depth) 13.4" (width) x 3.7" (height) x 14.8" (depth)
Weight:	Generator: 7.6 kg Transport case: 13.8 kg (loaded with generator) Transducer: 0.37 kg
Fuse Type:	T5A, 250 V, 20 mm (2 off)
Cordset	Contact RSL for recommended type
Power supply input	100V – 240 V, 50/60 Hz
Power consumption	200 VA
Cement Output - Frequency of operation	36k Hz
Cement Output – Power	<150 W
Cement Mode of Operation	Intermittent ON / OFF, 20/20 s
Cement Transducer Classification:	Type BF
Insulation Classification	Generator: Class 1
Transducer	Titanium, stainless steel, and plastic. Autoclavable maximum 50 cycles.
Environment for Transportation & Storage: (Except T1AH – Sterile Handpiece)	Temperature: -10°C to +50°C Relative humidity: 10% to 90% Atmospheric pressure: 50 kPa to 106 kPa
Environment for Storage of T1AH Sterile Handpiece:	Temperature: +10°C to +35°C Relative humidity: 30% to 50% Atmospheric pressure: 50 kPa to 106 kPa
Environment for Use:	Temperature: +10°C to +30°C Relative humidity: 30% to 75% Atmospheric pressure: 81 kPa to 106 kPa
TORS has been designed and built-in accordance with ISO 13485: 2016 Quality Assurance standard for medical devices.	
CE conformance has been certified and the equipment complies with: IEC 60601-1:2005 + CORR. 1:2006 + CORR.2:2007 + A1:2012 EN 60601-1:2006 + A11:2011 + A1:2013 ANSI/AAMI ES60601-1:2005/ (R) 2012	

Appendix 7: Warranty Statement

Subject to the terms and conditions listed in the warranty document (available on request), Radley Scientific Ltd. (hereafter called "the Company") guarantees to replace or repair free of charge any defective parts of TORS notified within the warranty period. This applies to the hardware defined below for the purposes of warranty claims made by any party supplied directly by the Company or its authorized representative.



CE
2797

UK
CA
0086



Bremridge House,
Bremridge,
Ashburton
S. Devon
TQ13 7JX
UK

Tel: +44 (0)1364 653899 – Helpline

www.tors.co.uk



endocon GmbH
In der Au 5
Wiesenbach
69257
Germany